

IAC-19-C2.2.10

Development and Testing of an Antenna Deployment System for Nanosatellite Applications Chintan Malde^{a*}, Sundar Gurumurthy^a, Ritika Diwan^a

^a Department of Mechanical Engineering, Birla Institute of Technology and Science Pilani, Pilani, Rajasthan, India, 333031, <https://www.bits-pilani.ac.in>

* Corresponding Author

Abstract

This paper presents the development of a tape antenna deployment system by students of Team Anant, BITS Pilani for their 3-U nanosatellite. The antenna arrangement to be deployed consists of a turnstile antenna and a monopole to achieve full duplex communication. The antenna deployment system should also contain a feedback mechanism. Several deployment systems were considered for this purpose. These systems varied in their deployment and feedback mechanisms, materials and antenna orientations. The tests were designed to check errors and delays in deployment, probability of failure, reliability of the feedback mechanism and limit loads. For coiled antenna stowage, the contour of the support was varied, and 3D printed for testing the deployment success rates for each contour. Whereas for wraparound antenna stowage, different constraining methods were tested. Results from the tests and analysis carried out are discussed and compared. This comparison is used to determine the deployment mechanism, feedback mechanism and materials to be used in the deployment system. A brief description of the finalised antenna deployment system has also been provided.

Keywords: Nanosatellite, Antenna Deployment, Coiled Tape Antenna

Acronyms/Abbreviations

CDS	CubeSat Design Specifications
FEM	Finite Element Method
FPGA	Field Programmable Gate Array
LV	Launch Vehicle
OBC	On-Board Computer
P-POD	Poly-Picosatellite Orbital Deployer
RF	Radio Frequency
TT&C	Telemetry Tracking & Tele-Command
UHF	Ultra-High Frequency
VHF	Very High Frequency

Over the years, several antenna deployment systems have been developed to overcome the limitations of nanosatellites. Many of these systems have been flight tested and much has been learned from their failures and successes. However, implementing already designed systems and structures into a satellite becomes difficult as satellite buses vary largely with payloads. For such missions, the concepts and learnings from such past researches must be applied to design the most suitable and reliable mechanisms. This paper details such an approach to design a tape antenna deployment system for the 3U nanosatellite.

The specific mission requirements and structural constraints have been studied to find the parameters necessary to determine the optimal system. Different technologies for various components of the deployment mechanism have been compared based on these combinations. Selected combinations were then designed and manufactured using 3D printing for rapid prototyping. Final design choices have been made based on the results of testing and analysis.

1. Introduction

Team Anant is the student satellite team of BITS Pilani. The team was established under the Student Satellite Program by Indian Space Research Organisation with the aim of developing a 3U CubeSat with hyperspectral imager as the primary payload and a FPGA based System on Chip as the secondary payload to be used for onboard compression of the image. The satellite will be used to image ocean surfaces for the estimation of Carbon Dioxide levels.

2. Constraints and Requirements

2.1 General CubeSat Requirements

As per the [4] CDS(The CubeSat Program, Cal Poly SLO, 2015), several standards have to be maintained while developing a CubeSat. These standards define the following restrictions for an antenna deployment system to be used in a CubeSat:

- *Clause 3.2.4:* Deployables shall be constrained by the CubeSat, not the P-POD.

- *Clause 3.3.1:* The CubeSat power system shall be at a power off state to prevent CubeSat from activating any powered functions while integrated in the P-POD from the time of delivery to the LV through on-orbit deployment. CubeSat powered function include the variety of subsystems such as Command and Data Handling (C&DH), RF Communication, Attitude Determine and Control (ADC), deployable mechanism actuation. CubeSat power systems include all battery assemblies, solar cells, and coin cell batteries.
- *Clause 3.4.4:* All deployables such as booms, antennas, and solar panels shall wait to deploy a minimum of 30 minutes after the CubeSat's deployment switch(es) are activated from PPOD ejection.
- *Clause 3.4.5:* No CubeSats shall generate or transmit any signal from the time of integration into the PPOD through 45 minutes after on-orbit deployment from the P-POD. However, the CubeSat can be powered on following deployment from the P-POD.

2.2 Mission Requirements

The deployment system must also meet the mission specific requirements of all the subsystems. The subsystem specific requirements coherent with each other and with the general requirements. If not, a compromise must be reached on the mission requirements.

2.2.1 Telemetry Tracking & Tele-Command requirements

The TT&C would be the subsystem utilizing the antenna for transmission of signals to and from the ground station. The antenna must meet the frequency requirements of the onboard and ground station communication architecture i.e. the antenna must be compatible with full duplex VHF and UHF transmission.

The antenna must further meet the gain requirements for optimal data transfer. To satisfy this condition, the antenna placement on the satellite should ensure a favourable radiation pattern. The radiation pattern must be highly directional for data downlink and should be omnidirectional for uplink. The polarization of the signal caused due to the antenna arrangement will also affect this factor.

Based on these constraints, the following design choices were made for the antenna configuration:

- Downlink must be done through a turnstile antenna with elements of length 14.5mm. This would provide circular polarization to limit polarization loss. Due to presence of 4 antenna elements, this arrangement would also provide added redundancy to the system.

- Uplink must be done with help of a monopole antenna of length 51.25mm. This would ensure that the uplink is omnidirectional.

2.2.2 Structure and Thermal Requirements

The deployment system is to be accommodated into the structure of the CubeSat. Hence the structure of the deployment must be compatible with the mechanical requirements of CDS [4] (The CubeSat Program, Cal Poly SLO, 2015). The components of the deployment must be positioned such that they do not interfere with the FOV of the payload. Since the antenna is a magnetic field generating component, it must be magnetically shielded from onboard electronic and magnetic components.

The size of the deployment must be limited to 96.4 x 96.4 x 30 mm. The deployment should cover an area of less than 7750 mm² on the outer faces to ensure enough area for body mounted solar panels.

2.2.3 On-Board Computer Requirements

The OBC needs to know about the state of deployment of antenna elements to execute the flight plan accordingly. On failure of deployment of one or all the elements, the OBC must restart the deployment sequence. If some elements are not deployed even after a fixed number of attempts, the OBC will direct the TT&C to execute the most suitable flight plan.

2.2.4 Power System Requirements

The antenna deployment should have a maximum power usage of 7.5W.

3. Components of Deployment System

3.1 Antenna Elements

The antenna elements usually used in CubeSats can be classified into 2 categories:

- *Rigid Elements:* Rigid elements are favourable for use in CubeSats as they are not easily deformed by launch loads. However, any rigid element must be smaller than the longest dimension of the satellite to be completely constrained by the structure.
- *Tape Spring Elements:* Tape spring elements are subject to deformation due to external forces, but they can be folded or rolled. This allows them to be constrained inside structures which are much smaller than their length.

Due to the length of the monopole being longer than the longest dimension of the CubeSat, using a tape spring element was the only option. To keep the system uniform and reduce complexity, tape springs were also finalised for the shorter turnstile elements.

3.2 Stowage Methods

The tape spring elements must be stowed inside the structure for deployment. The stowage can be done using two well established methods.

- *Wrap Around Stowage:* In this method of stowage, the antenna elements are wrapped along the structure of the satellite. The elements are then deployed using burn resistors. The major advantage of this method is that it is compact. However, in this method, stress is concentrated on a very small region of the element. This increases the risk of permanent deformation. The tying of burn resistors directly to the element and the outside surface of the satellites can damage the solar panels as well as the antenna elements. The monopole antenna element would obstruct the payload field of view in the stowed condition. Hence on failure of deployment the payload will not be able to function.
- *Coiled Stowage:* In this method the antenna elements are coiled and placed inside a deployment module. The deployment module is designed with a contour which constrains the motion and hence directs the deployment of the element when set free. The need for a module increases the space requirements. Furthermore, the contour constraining the motion of the element must be designed with care to not obstruct the deployment. However, the antenna elements are well protected inside the module.

The choice of optimal stowing method is not straightforward. This choice is to be made based on a multitude of parameters because of how different these methods and their outcomes are. Hence, it is necessary to quantify the disadvantages. For this purpose, the wrap around antenna configuration was simulated for internal stresses and stress concentration using FEM. This simulation was done as a part of a separate project and goes beyond the scope of this paper.

From these simulations, it was observed that the sharp edges of the outer panels can cause the internal stresses of the elements to increase. To reduce this, the outer edges must be filleted to reduce the stress concentration [2] (Marholm, 2012), or a support structure must be provided [1] (Lankinen, 2015). Providing such support structures would increase the size of the system, akin to a coiled stowage, but without its advantages. Hence, coiled stowage is the better method for the required antenna dimensions. This, however, is subject to design and testing of the module.

4. Designing of Deployment System

Based on the discussions and considerations of various components of the deployment system, the following design choices were made:

- Stowage to be done using coiled elements
- Burn resistors to be used for deployment actuation
- Feedback was to be received using switches

[3] (S B M Zaki, 2019) and several others have designed different coiled stowage deployment systems for CubeSats. These designs have been consulted to design our own deployment system.

Three modules with these characteristics were designed and tested. These three systems varied in their implementation and stowage of the antenna, the positioning of the feedback switches and the space occupied in the CubeSat as available space is one of the major constraints faced. A brief description of the 3 systems and their dimensions is given below.

4.1 Module 1

This was the most primitive of the 3 designs shortlisted, the monopole and the turnstile antenna were stowed in two different modules. This increased the modularity and the redundancy of the system as both antenna stowing modules can be operated independently of each other. However, the combined space consumed by the two different modules was very large which reduced the space available to other components. Also, this system required the use of 5 deployment switches placed on top of each of the modules.

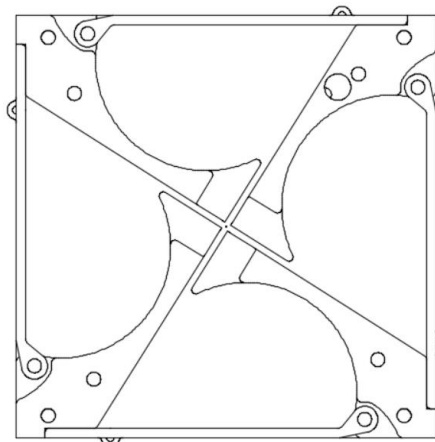

Figure 1: Turnstile housing of test module 1

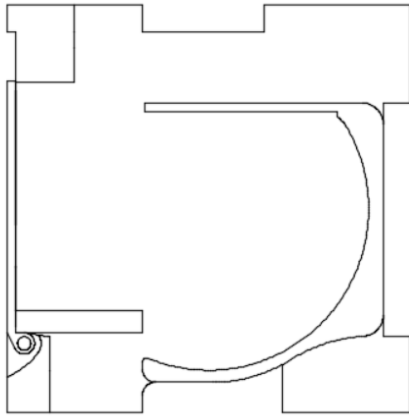

Figure 2: Monopole housing of test module 1

4.2 Module 2

To conserve space the two stowage modules were combined into one single entity housing the monopole at one side and the turnstile at the other side of the same module. This also reduced the number of deployment switches required to 4. A single nylon wire can now be wound around 2 opposite gates thereby reducing the number of heating resistors required to just 2. The radius of curvature of the monopole stowing attachment was lowered to reduce the stresses acting on the coiled antenna in the stowed state. This also provided more room to accommodate the long monopole antenna.

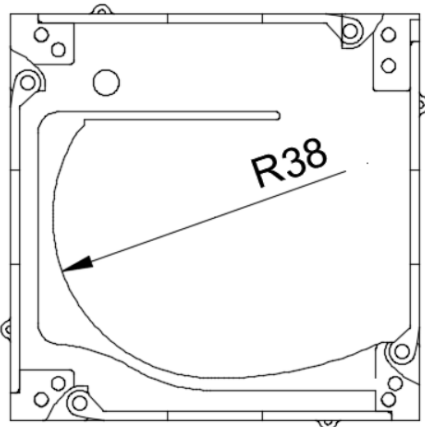

Figure 3: Monopole housing of test module 2

4.3 Module 3

The third module design was an iterative update of the design of module 2. The same concept of housing both the antenna on the opposite sides of the same stowing module was used. The radius of curvature of the monopole housing was increased thereby providing a much smoother path for the opening motion of the antenna. The area covered by the housing was also reduced making the antenna more tightly coiled. This increased the chances of permanent deformation of the antenna due to the stresses. However, the increased

stresses also increased the tendency of the antenna to regain its original form.

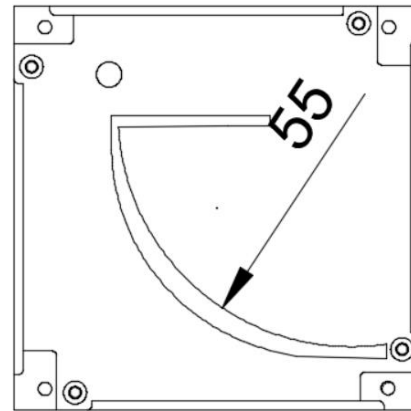

Figure 4: Monopole housing of test module 3

5. Testing of the modules

5.1 Test Setup

The shortlisted deployment systems were thoroughly tested for their probability of failure and the reliability of the deployment mechanism. The test setup was designed to minimize human errors and hence maximize the reliability of the results. The test setup involves mainly two parts, the deployment circuit and the mechanical setup of the module.

5.1.1 Deployment Circuit

The deployment circuit works on the phenomenon of heating of resistor to produce heat which in turn burns the nylon wire wound around it. The deployment circuit consists of four major components the MOSFET gate, the TI MSP430 microcontroller to control the opening and closing of the gate, the resistor to be heated to burn the nylon wire and the feedback switch which generates an interrupt in the microcontroller to signify the opening of the gate. The working of the deployment circuit is fairly simple. The gate of the MOSFET will be connected to the output pin of the microcontroller, the drain of the MOSFET will be connected to V_{cc} through a 10ohm resistor and the source will be connected to the ground. The lower resistance value is used to maximize the current flowing and hence increase the heat generation.

The microcontroller controls the opening and closing of the gate. The gate is closed periodically to prevent the overheating and burning of the resistor. The increase in V_g results in the opening of the channel and the current starts flowing through the resistor. As a result, the resistor gets heated up heating up the nylon wire and eventually burning it. The feedback switches initially in the closed position will be connected between the ground and the input pin of the

microcontroller. The switch initially in the closed position will be grounding the input pin when the switch will open the connection to the ground is cut leading to a voltage drop across the resistor which will produce an interrupt in the microcontroller and hence detect the opening of the gate.

The deployment switch will be integrated into the module in case of the third design whereas it will be resting on the deployment circuit board for the other 2 cases.

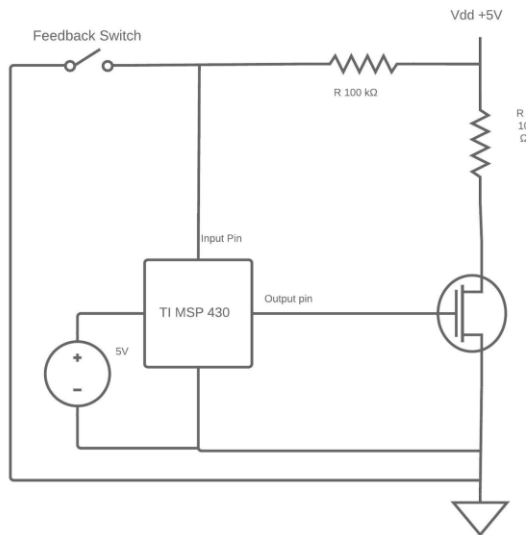

Figure 5: Deployment circuit diagram

5.1.2 Mechanical Setup

The mechanical setup includes the integration of the antennas in the module, the fixing of the deployment module, the integration of the deployment switch and the connection of the nylon wires. The monopole and the turnstile antenna were connected to the module with the help of screws. Two holes were drilled in the tape springs and the antenna elements were screwed to the walls of their respective stowing chambers. The whole deployment module was fixed to a base with the help of screws so that the module does not move due to the reaction forces of the antenna opening. The module was mounted at the edge of a table to allow free motion in the y-direction for the opened antenna trying to simulate the condition it will observe while placed in the CubeSat. In the case of the first two modules, the deployment switches were placed on the upper cover plate of the modules. The switches were kept in a closed position by pressing against the raised faces of the gates. In case of the 3rd test module, the monopole side of the stowage had enough place to house the switches while not interfering with the antenna. The deployment circuit was housed on the top cover of the deployment module.

The nylon wire was run through the holes provided in front of the gates and wound around the resistor. Two opposite gates were wound with the same nylon wire thereby reducing the material used and the power required for the deployment.

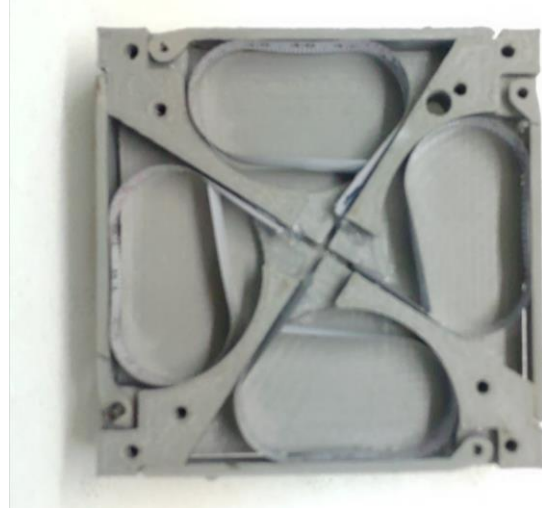

Figure 6: Testing setup for module 3

5.2 Test Results

The test results were tabulated in Table 1 at the end of the paper.

6. Discussion

The obtained results suggest that module 3 is the most reliable of the three modules. However, it is necessary to understand why the other modules didn't perform so well.

In module 2, it was observed that the monopole antenna would get stuck at the end of the directing arc repeatedly. This can be due to the high curvature of the contour. The large curvature was not properly constraining the antenna when released and hence the antenna was not moving along the intended path. The large curvature also caused an increase in the internal stress on the tape spring. This could lead to deformation of the element when it hits the end of the arc.

In module 1, the gates were being obstructed due to the low clearance with the upper and lower plates. This reduced the probability of deployment significantly. A problem like module 2 was also observed on the monopole element.

7. Conclusions

Several antenna deployment modules were designed based on mission specific and general parameters. These modules were tested to find the most suitable deployment system.

Acknowledgements

The authors would like to thank all present and former members of Team Anant for their continued support and technical guidance.

This work would not have been possible without funding and infrastructural support from BITS Pilani. The authors would also like to thank the administration of the institute and the faculty mentors of Team Anant.

References

[1] Lankinen, M. (2015, November 18). Design and Testing of Antenna Deployment System for Aalto-1 Satellite (Master's Theises). Aalto University.
 [2] Marholm, S. (2012, July). Antenna System for NUTS (Master's Theises). Norwegian University of Science and Technology.

[3] S B M Zaki, M. H. (2019). Design, Analysis and Testing of Monopole Antenna Deployment Mechanism for BIRDS-2 CubeSat Applications . *Journal of Physics: Conference Series 1152*.
 [4] The CubeSat Program, Cal Poly SLO. (2015, April 6). *Developer Resources*. Retrieved from <http://www.cubesat.org/resources>

	Module 1		Module 2		Module 3	
	Monopole	Turnstile	Monopole	Turnstile	Monopole	Turnstile
all gates opened successfully	86	79	100	100	100	100
Antenna deployed successfully	54	79	42	100	91	100
Feedback Received	100	100	100	100	100	100
false Positive	32	0	58	0	9	0
Probability of successful Deployment	54	79	42	100	91	100
Probability of successful Detection	62.7907	100	42	100	91	100

Table 1: Results